

SANTA MARGHERITA LIGURE > GENOVA • ITALY VILLA DURAZZO

7 > 9 OTTOBRE/OCTOBRE 2016



Santa  
Margherita  
Ligure  
IN  
MARE DI FIORI

CONCORSO INTERNAZIONALE DI DECORAZIONE FIOREALE



Camera di Commercio  
Genova



Ente  
Decorazione  
Florale per  
Amatori - Genova

INTERNATIONAL  
FLOWER SHOW



# Santa Margherita Ligure

SUN  
MARE

DI FIORI

OCTOBER 7 > 9, 2016

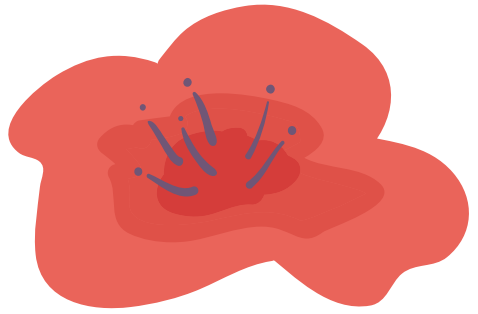

## EVENTS SCHEDULE INTERNATIONAL SHOW

Classes

Prizes

General rules

"Nuovo Stile" rules

Organization

VILLA DURAZZO

EXCURSIONS

INFO



# EVENTS SCHEDULE

OCTOBER 7 > 9, 2016

## INTERNATIONAL SHOW

### THURSDAY 6

Registration ..... 03.00 pm - 07.00 pm

### FRIDAY 7

Registration ..... 08.30 am - 10.30 am

Participants work ..... 08.30 am - 1.00 pm

Jury's work ..... 02.00 pm - 05.30 pm

Opening ..... 07.00 pm

Prizes giving ..... 07.30 pm

Gala dinner ..... 08.30 pm

Opening to the public - free entrance

**SATURDAY 8** ..... 10.00 am - 8.00 pm

**SUNDAY 9** ..... 10.00 am - 6.00 pm

## DEMONSTRATIONS VILLA DURAZZO

By Paola Zattera Dagnino, teacher, demonstrator, international judge and passionate cook. Limited seats.

### SATURDAY 8

Halloween centerpiece ..... 11.00 am - 12.00 am ..... € 15,00

Happy hour and finger foods ..... 06.00 pm - 07.00 pm ..... € 20,00

with tasting

### SUNDAY 9

Christmas decorations ..... 11.00 am - 12.00 am ..... € 15,00

Merry Christmas! ..... 04.30 pm - 05.30 pm ..... € 15,00

Flower design for a Christmas buffet

# INTERNATIONAL SHOW

## CLASSES

All measurements are in centimeters, competitors may choose 1 or 2 classes:

### Class 1 SEDUCTIVE DESIGN

*Free design, large dimensions exhibit  
inspired by the architect Renzo Piano works*

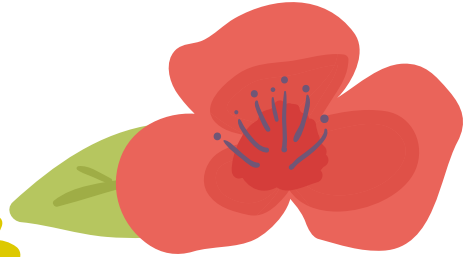

- a) Open to amateurs.
- b) Open to professionals, judges, teachers, demonstrators.
  - Minimum height 180 cm base and container included.
  - Maximum height 230 cm base and container included.
  - Maximum width 150 cm.
  - Base 120x120x2 cm - white fabric.
  - Viewed from all around and judged from the front.

*Two competitors for a single exhibit are admitted.*

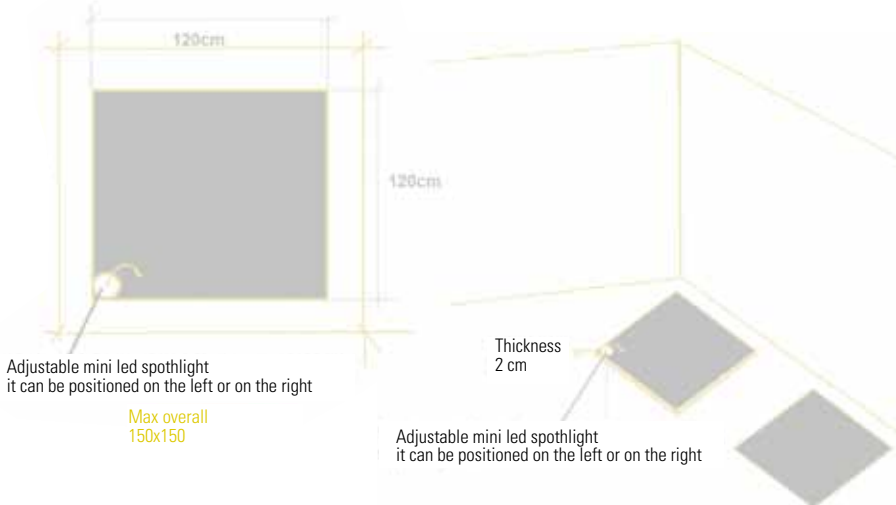

## Class 2 RED AND BLACK

**Abstract exhibit inspired by the works of painter Emilio Scanavino**

On a table 90 cm l x 65 cm d.x. 76 h covered with white fabric  
Maximum high 120 cm

- Open to amateurs.
- Open to professionals, judges, teachers, demonstrators  
Viewed from all around and judged from the front.

tables with 3 workspaces

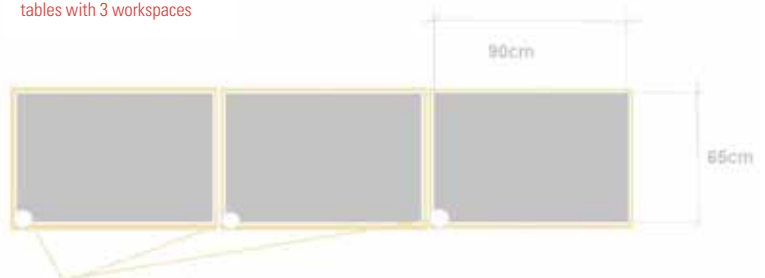

Adjustable mini led spotlight  
it can be positioned on the left or on the right



## Class 3 GREEN GOLD

*Free exhibit inspired by "pesto genovese", centerpiece*

A rectangular table, 150 cm x 75 cm and 74 cm high, will be provided on place by organizers. Competitors must supply their own floor length table cloth. Viewed from all around and judged from the front.



Adjustable mini led spotlight it can be positioned on the left or on the right

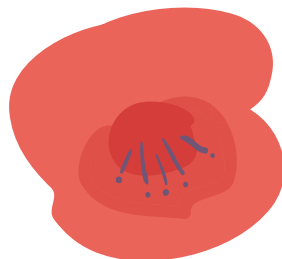

## Class 4 "OSSI DI SEPIA"

### ***New style exhibit dedicated to the poet Eugenio Montale***

- a) Open to amateurs.
- b) Open to professionals, judges, teachers, demonstrators

The use of non-vegetable materials such as shells, stones, cloth, tape, rope, metal, glass, plexiglass, is permitted with moderation but they must not predominate and they are considered accessories.

On a table 75 cm x 75 cm x 74 cm h, covered with white fabric;  
maximum high 120 cm.

Viewed from all around and judged from the front.

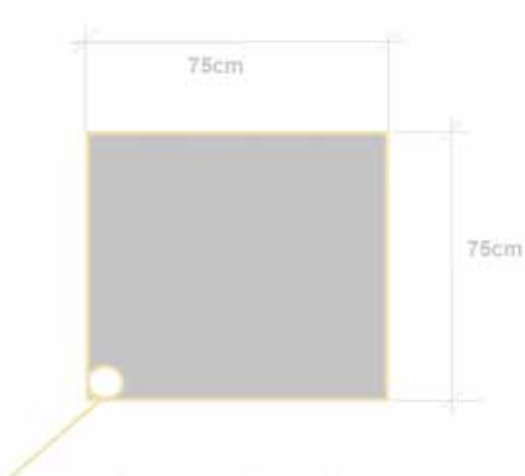

Adjustable mini led spotlight it can be positioned on the left or on the right



INTERNATIONAL SHOW



## Class 5 "CREUZA DE MA"

*Landscape, dedicated to the songwriter Fabrizio de André*

Landscape exhibit, on a table 70 cm l x 50 cm d, 76 cm h, covered with white fabric; maximum high 120 cm. Viewed from all around and judged from the front.

tables with 2 workspaces

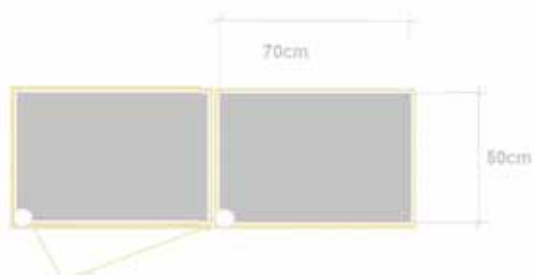

Adjustable mini led spotlight  
it can be positioned on the left or on the right

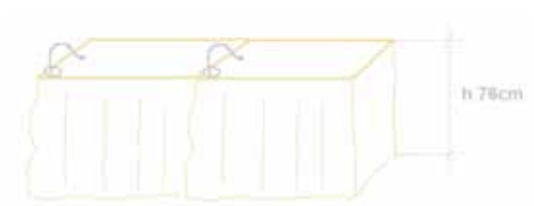

INTERNATIONAL SHOW

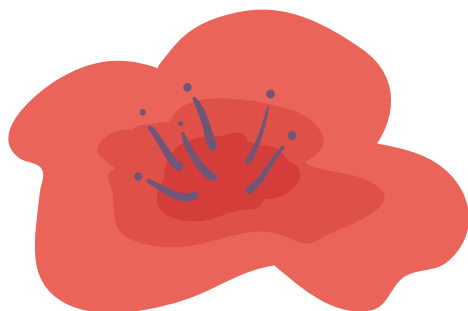

## Class 6

# BALL AT VILLA DURAZZO

*Free exhibit, "bal en tête", headpiece for a ball*

Headpiece for a ball, on a cm. 50 x 50 x 85 h. base, covered with white fabric.

Maximum space available cm. 80 x 80 x 120 h.

Viewed from all around and judged from the front.



Adjustable mini led spotlight, cm. 12 diameter,  
it can be positioned on the left or on the right.

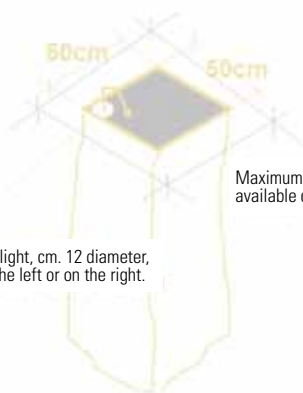

Maximum space  
available cm. 80 x 80.

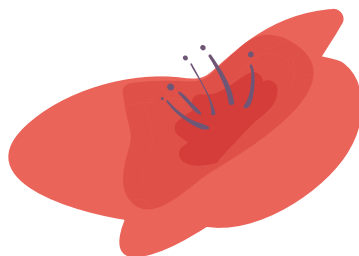

*Free exhibit inspired by the works of the painter Rubaldo Merello, on a easel*

- a) Open to amateurs.
- b) Open to professionals, judges, teachers, demonstrators.

Competitors are allowed to fix the mechanic on the wood board

Adjustable mini led spotlight  
it can be positioned as your wish

h 60 cm

l 90 cm

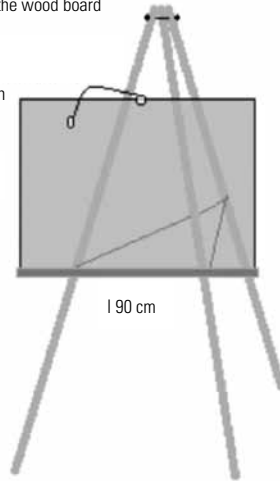

height from the floor 80 cm  
wood board thickness 1 cm  
covered whit jute



## Classe 8 "CAPRICCI"

*Free exhibit dedicated to the composer and violinist Niccolò Paganini*

On a table 90 cm l x 65 cm d., covered with white fabric; maximum high 120 cm.  
Viewed from all around and judged from the front.

tables with 3 workspaces

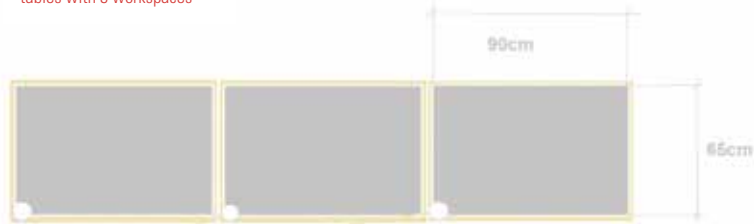

Adjustable mini led spotlight it can be positioned on the left or on the right



# PRIZES

The show will be judged by an international jury that will award for each class:



**The Best in Show that is kindly offered by the Istituto Italiano di Decorazione Floreale per Amatori (I.I.D.F.A.) - Sanremo**



The show will be judged by an honor jury that will award the prizes:



*"Elegance"*



*"Originality"*



*"Colors harmony"*

**"Santa Margherita Prize", offered by Municipality of the Town for the exhibit better interpreted the chosen class.**



**Sunday, October 9 at 6.00 pm will be awarded the prizes:**



*For the best conservation*



*Public*

# GENERAL RULES

- 1) **The show is for amateurs:** autodidacts, students and who do not give any kind of lessons and that they do not receive compensation. **Professionals:** professionals, judges, teachers and demonstrators, are admitted in classes 1b, 4b, 7b.
- 2) **It is compulsory for professionals to declare their qualification on the entry form.**
- 3) Exhibits must be entirely staged **in situ**, without any internal or external assistance, within the time allowed, in the assigned place and within the given dimensions.
- 4) The exhibited design must be completely unedited and therefore never presented in other competitions or exhibitions and it must be stated on the registration form.
- 5) Accessories are allowed but plant material must always **predominate**.
- 6) Cut plant material must be kept in water or water retaining material except for: grass, moss, succulents, cactii, lichens, fruits and vegetables but should be perfectly conditioned
- 7) Dying or painting fresh plant material is prohibited.
- 8) The use of artificial plant material and led lights is not allowed.
- 9) Mechanics as: wires, net, pin holder, oasis etc. must not be visible except for Class 4 "new style", see specific regulation. The use of the colored oasis in view is prohibited in every case
- 10) E 'strictly prohibited to attach any element (niches, panels or other) to the wall behind the exhibit or on to the base. The background panels are allowed, but must be self-supporting because nothing can be attached to the wall behind it or on to the base.  
Only in class 7, competitors are allowed to fix their mechanic on to the given wood board.
- 11) The height, width and depth of the exhibit must never exceed the allotted space.
- 12) No competitor will be allowed to remain in the exhibition area after 1.00 p.m. The entry in the competition area is forbidden during judging.
- 13) It is 'strictly prohibited to use:  
Instant print cameras, cell phones, smart phones and tablets during the construction of the exhibits and before the passage of the juries. The E.D.F.A. reserve the right to reproduce photographically the exhibits and use them for institutional purposes.
- 14) The exhibit staged not conformingly with competition rules will be downgraded.
- 15) Exhibits are judged anonymously.
- 16) The jury's decisions will be final.
- 17) Competition will be judged in accordance with the B.F.A.S. international competitions rules (Belgium).

# "NUOVO STILE" RULES

- 1) Interpretation of the theme.
- 2) Free design, the lines may start from several points.
- 3) Value of the design.
- 4) Color.
- 5) Harmony.
- 6) In the report container / plant material, container may predominate.
- 7) The container can be classic, modern, fantasy or period, it is allowed to use more than one container. It is possible to create designs without container as well.
- 8) Conditioning of the fresh plant material.
- 9) Wire, tubes, wire net, may be visible if they are used as decorative elements, but should not predominate.
- 10) The stems may cross.
- 11) Originality.
- 12) Dried plant material is allowed, but must not predominate.
- 13) If you use a background, it must contribute to the value of the composition, but should not predominate.

# ORGANISATION

- 1) Only written applications using the enclosed entry form joint with the correct enrolment fees will be registered; applications must reach the Studio BC before **September 2<sup>nd</sup> 2016**. The places in each class are limited therefore applications will be accepted in order of arrival date. The organizers reserve the right to cancel some classes if necessary, competitors will be promptly informed and refund of the entry fees.
- 2) Competitors may present only one exhibit for each class. According to the number of places available, competitors may present an exhibit in two classes giving order of preference. The organizers reserve the right to cancel the second exhibit. In this case the organizers will inform promptly the competitor. Confirmation of applications will be sent after September 2<sup>nd</sup> 2016.
- 3) Two competitors may join for a single exhibit only in the classes 1A and 1B; in this case they must send only one entry form.
- 4) Enrolment fees are fixed in euro 35.00 VAT included for all classes; The payment should be done upon application. Registered competitors that could not compete, must inform the Studio BC as soon as possible. Entrance fees will be kept.
- 5) To each competitor will be sent a strictly personal badge that will get him into competition area. The badge must be shown at the entrance during the opening days of the Competition. **Only people showing this badge will be allowed to stay in the competition area during staging time.**
- 6) Competitors must stage their exhibits on **October, Friday 7<sup>th</sup> 2016, from 8.30 a.m. to 1.00 p.m.**  
Competitors registration will be:
  - Thursday October 6<sup>th</sup> 2016 from 3.00pm to 7.00pm
  - Friday October 7<sup>th</sup> 2016 from 7.00am to 10.30amCompetitors must leave the competition area at 1.00 p.m.  
Places will be reserved until 10.30 a.m. There will be some porters that will help competitors to carry the items.
- 7) The places fixed to competitors cannot be changed. The organizers reserve the right to move the exhibits if necessary.
- 8) Competitors must clean the niche or the dedicated place themselves
- 9) The use of self developing cameras is forbidden during the exhibits staging and before Jury's work. E.D.F.A. reserves the right to photograph and reproduce the exhibits.
- 10) The Studio BC decline all responsibility for loss or damage to competitors property. No insurance will be taken by the organization.
- 11) Exhibits will be judged in absence of competitors by an international technical Jury and a honour Jury.



12) The show will be open to public:

- Saturday 8<sup>th</sup> from 10.00 a.m. to 8.00 p.m.,
- Sunday 9<sup>th</sup> from 10.00 a.m. to 6.00 p.m.,

Competitors undertake to maintain in good conditions their exhibits until Sunday 9<sup>th</sup> October, 6.00 p.m.

Organizers reserve the right to remove faded plant materials, in case that the competitor does not provide himself daily before from 9.00am to 10.00 a.m.

13) The price-giving ceremony will take place on Friday, October 7<sup>th</sup> at 7.30 p.m.at Villa Durazzo. After the ceremony there will be a gala dinner if competitors wish to participate, please fill the enclosed reservation form and send it to Studio BC., joint with the payment of euro 85,00 per person, V.A.T.. included, before **September 2<sup>nd</sup> 2016**.

14) Exhibits must be removed by competitors themselves on Sunday, October 9<sup>th</sup> 2016 between 6.00 pm.and 7.00 pm. showing to organizers the ticket that which will be delivered at the time of registration. If the competitors couldn't be able to remove himself the exhibit, the ticket will be requested from his representative by organizers.

15) Signing the entry form, competitors declare their agreement with the rules and organization.

# VILLA DURAZZO

SANTA MARGHERITA LIGURE

## Venue of the events

S. Margherita Ligure, pearl of the Gulf of Tigullio, at few Kilometers from the universally known Portofino, is the venue of the Prize in the charming setting of Villa Durazzo. The Villa Durazzo complex, dominating the scene in the centre of S. Margherita Ligure, just above the Harbour and sea, comprises Villa Durazzo, Villa S. Giacomo and the splendid Gardens, which enclose them all. The Castle and the Baroque Church of San Giacomo are very close to them. In a dominating position over the sea, Villa Durazzo was built in 1678 and there, today, you can admire the works of the Genoese Pictorial School from the XVII and XVIII centuries: frescoes and trompe-l'oeil, furniture from various ages, Murano chandeliers, stuccoes, majolica and Genoese grit floor. The Gardens are included in the circuit of "Great Italian Gardens" and are twinned with the Botanical Gardens of Villa Hanbury in Ventimiglia. Overlooking the Gulf, they are enriched by statues and fountains. Splendid the black and white cobbling of the Villa Terrace, in the style of the "risseu", typical Ligurian paving. Villa San Giacomo is an eighteen century cottage in the ground of Villa Durazzo, which looks out onto the panoramic Italian Garden.



# EXCURSIONS

## EXCURSIONS SATURDAY OCTOBER 8 • AFTERNOON

### PORTOFINO COAST IS ONE OF THE MOST CELEBRATED AREAS OF NATURAL BEAUTY IN ITALY.

This fascinating and exclusive coast with its lively, colourful fishermen's villages, enchanting promontories, sheltered bays and little coves is given further charm by a real gem: the Benedictine Abbey of San Fruttuoso (end of 10th century), on the UNESCO World Heritage List.

In order to make it more enjoyable, this tour - by coach and by boat - will be organized in groups that will be able to walk through the villages and admire the coastline from the boat (*in case of bad weather or rough sea the visit to San Fruttuoso will be substituted by the visit to Cervara Abbey*). The tour will end in Portofino, one of the most famous destinations of international tourism, a fishermen's village so picturesque as to appear unreal.

- Cost x person V.A.T. included € 65,00
- Minimum 20 participants



## IN ALTERNATIVE

### GENOA AND ITS PALACES

Genoa: many places and sights are worth to visit in Genoa, especially in the old city centre, the largest in Europe. The tour takes in some of the most impressive streets and museums: Via San Lorenzo, Piazza San Matteo the beautiful Doria houses, Via Garibaldi, the grand Renaissance street which fascinated artists such as Peter Paul Rubens, lined with imposing residences built at the end of the XVI century by the city's wealthiest merchant families. Formely Strada Nuova, on the UNESCO World Heritage List, it is more than a road: it is a quarter built in the second half of the 16th century by the most influential and affluent families in Genoa.

Visit of Palazzo Nicolosio Lomellino and its secret garden (private palazzo) Caffè e tea in historical inn. Transfer by coach

- Cost x person V.A.T. included € 70,00
- Minimum 20 participants



# INFO

## ORGANIZING SECRETARY

*For inscriptions, hotels reservations and excursions.*

Studio BC has available allotment of rooms in 3 and 4 star hotels in Santa Margherita Ligure. Fares and info upon request.

A copy of the registration forms and payment form must be sent to:

### **Studio BC**

Via di Santa Chiara 2/11 - 16128 Genova

Tel. +39 010 0983860 • Fax +39 010 0983864

info@studiobc.it

Bank directions BANCA REGIONALE EUROPEA - Filiale 01521 Genova (IT)

IBAN: IT26B069060140000000030092

SWIFT CODE: BREUITM1

Download of registration forms also available on: [www.studiobc.it](http://www.studiobc.it)



## TECHNICAL SECRETARIAT

*Technical secretariat for all information on the show, workshops and demonstration:*

### **Paola Zattera Dagnino**

Director of events

paoladagnino@hotmail.com

(Object: Concorso Santa Margherita)

cell. +39 3357050590

# REGISTRATION FORM FOR THE COMPETITION

(Capital letters)

Be sent by **SEPTEMBER 2<sup>ND</sup> 2016**  
TOGETHER WITH PROOF OF PAYMENT to  
Studio BC - info@studiobc.it

Surname ..... Name .....  
Address ..... Zip code ..... Town ..... Country .....  
E-mail ..... Phone ..... Fax .....  
V.A.T. nr. .... Club .....

Qualification (see General Rules points 1 and 2):  Amateur  Professionals

*2nd competitor, only for class 1A and 1B.*

Surname ..... Name .....  
Address ..... Zip code ..... Town ..... Country .....  
E-mail ..... Phone ..... Fax .....  
V.A.T. nr. .... Club .....

Qualification (see General Rules points 1 and 2):  Amateur  Professionals

Please cross the class (es) selected as first or second choice, in case of classes 1,4,7, indicate options a or b.

	1 CHOICE	2 CHOICE	
CLASS 1	<input type="checkbox"/>	<input type="checkbox"/>	<b>SEDUCTIVE DESIGN</b> a) open to amateurs. b) open to professionals, judges, teachers, demonstrators (see General Rules points 1,2)
CLASS 2	<input type="checkbox"/>	<input type="checkbox"/>	<b>RED AND BLACK</b>
CLASS 3	<input type="checkbox"/>	<input type="checkbox"/>	<b>"GREEN GOLD"</b>
CLASS 4	<input type="checkbox"/>	<input type="checkbox"/>	<b>"CUTTIEBONES"</b> a) open to amateurs. b) open to professionals, judges, teachers, demonstrators (see General Rules points 1,2)
CLASS 5	<input type="checkbox"/>	<input type="checkbox"/>	<b>CREUZA DE MA</b>
CLASS 6	<input type="checkbox"/>	<input type="checkbox"/>	<b>BAIL AT VILLA DURAZZO</b>
CLASS 7	<input type="checkbox"/>	<input type="checkbox"/>	<b>COLOURS !!!</b> a) open to amateurs. b) open to professionals, judges, teachers, demonstrators (see General Rules points 1,2)
CLASS 8	<input type="checkbox"/>	<input type="checkbox"/>	<b>CAPRICCI</b>

## ENROLLMENT FEES

Class: € 35.00 V.A.T.inc.

I declare that in no case I can be considered as a professional, judge, teacher and demonstrator( see General Rules points 1 and 2 )not for classes 1b, 4b, 7b. I declare that I have read the General Rules and Organisation and I agree to comply with them. I declare that my exhibit is inedited.

Date

Signature

Italian law 196/03 "Treatment of personal data". Personal data are only treated for the organization and management of the Competition. They will not be communicated to any third party. Their modification or cancellation can be directly asked to the Organizing Secretariat.

# REGISTRATION FOR DEMONSTRATIONS

(Capital letters)

Be sent by **SEPTEMBER 2<sup>ND</sup> 2016** TOGETHER WITH PROOF  
OF PAYMENT to Studio BC - [info@studiobc.it](mailto:info@studiobc.it)  
Registrations will be accepted in the order of arrival.

Surname ..... Name .....  
Address ..... Zip code ..... Town ..... Country .....  
E-mail ..... Phone ..... Fax .....  
V.A.T. nr. .... Club .....

Demonstration at Villa San Giacomo by Paola Zattera Dagnino.  
Limited places we recommend to book in time.

## SATURDAY OCTOBER 8<sup>TH</sup> 2016

- Halloween centerpiece 11.00 am -12.00 am € 15,00 € \_\_\_\_\_
- Happy Hour and finger foods with degustation 6.00 pm - 7.00 pm € 20,00 € \_\_\_\_\_

## SUNDAY, OCTOBER 9<sup>TH</sup> 2016

- Christmas decorations 11.00 am -12.00 am € 15,00 € \_\_\_\_\_
- Merry Christmas!  
Flower design  
for a Christmas buffet 4.30 pm - 5.30 pm € 15,00 € \_\_\_\_\_

Total € \_\_\_\_\_



Date

Signature

Italian law 196/03 "Treatment of personal data". Personal data are only treated for the organization and management of the Competition. They will not be communicated to any third party. Their modification or cancellation can be directly asked to the Organizing Secretariat.

# SUMMARY OF REGISTRATION IN THE DEMONSTRATIONS

(Capital letters)

Be sent by **SEPTEMBER 2<sup>ND</sup> 2016** TOGETHER WITH PROOF  
OF PAYMENT to Studio BC - info@studiobc.it  
Registrations will be accepted in the order of arrival.

Surname ..... Name .....  
Address ..... Zip code ..... Town ..... Country .....  
E-mail ..... Phone ..... Fax .....  
V.A.T. nr. .... Club .....

## SHOW

FRIDAY 7 OTTOBRE 2016

ore 8.30  € 35,00 x exhibit x nr .... tot. € .....

## GAIA DINNER

FRIDAY 7 OTTOBRE 2016 Villa Durazzo

8.30 am  € 85,00 x person ..... x nr person tot. € .....

## DEMONSTRATION

OCTOBER, SATURDAY 8<sup>TH</sup> 2016

11.00 am - 12.00 am  Halloween € 15,00 x person x nr. .... persons tot. € .....

6.00 pm - 7.00 pm  Happy Hour € 20,00 x person x nr. .... persons tot. € .....

OCTOBER SUNDAY 9<sup>TH</sup> 2016

11.00 am - 12.00 am  Christmas decorations € 15,00 x person x nr. .... persons tot. € .....

ore 16.30-17.30  Christmas buffet € 15,00 x person x nr. .... persons tot. € .....

TOTAL ..... € .....

Date

Signature

The payment must be done to: Banca REGIONALE EUROPEA

IBAN: IT26B069060140000000030092 indicate: CONCORSO SANTA MARGHERITA

Date

Signature

Italian law 196/03 "Treatment of personal data". Personal data are only treated for the organization and management of the Competition. They will not be communicated to any third party. Their modification or cancellation can be directly asked to the Organizing Secretariat.